

# GREASE RESERVOIRS - REMOTE/WALL MOUNT

LUBE DEVICES' grease reservoirs are ideal for supplying positive displacement pumps such as the PMP100 or PMP200 (Bulletins F1837-1 and -2) when larger capacities are required than offered by the GCA100 or GCA200 Grease Cartridge Adapters (Bulletin F1867-1). These reservoirs feature: mounting brackets to minimize installation time, a conveniently located grease fitting for filling, an internal follower piston to prevent air passing through the grease to the outlet and a large outlet to minimize restriction when connecting to a pump. The reservoirs also feature a 40 micron air filter vent to minimize contamination. The clear reservoir provides a full 360° visual check of the grease level. The reservoir must be mounted vertically with the outlet down and must not be pressurized on the grease side or the vent side.

## STANDARD MATERIALS:

- Aluminum construction
- Buna N Seals
- Break resistant, colorless transparent acrylic

## OPERATING CONDITIONS:

- Maximum working temperature up to 160°F (71.1°C)
- Working pressure is from atmospheric to minus 29 InHg (737mmHg)

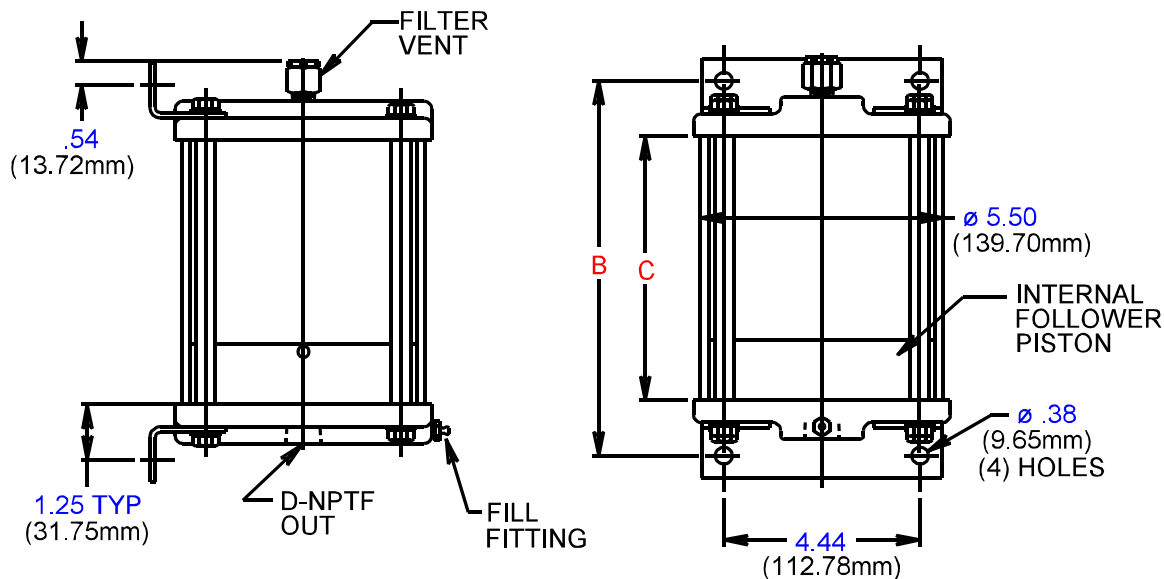

CATALOG NUMBER	CAPACITY [weight]	B INCHES (mm)	C INCHES (mm)	D Thread NPTF
GR75	75 cu. in. (1229 cu. cm.) [41 ounce (1.16kg)]	8.50 (215.90)	6.06 (153.92)	1/2
GR168	168 cu. in. (2753 cu. cm.) [91 ounce (2.58kg)]	13.25 (336.55)	10.69 (271.53)	1/2

GREASE RESERVOIRS  
REMOTE/WALL MOUNT  
BULLETIN F1867-2

12/02



**LUBE DEVICES, INC.**

1864 NAGLE AVE., P.O. BOX 1810, MANITOWOC, WI 54221-1810  
PHONE: (920) 682-6877 FAX: (920) 684-7210  
E-MAIL: sales@lubedevices.com WEBSITE: www.lubedevices.com