

# SPRAY VALVES - ALUMINUM BODY/ BRASS NOZZLE

Spray valves when used with series RVP100 pressure reservoirs, (see Bulletin F1097) will spray lubricant on bearings, rollers or chain. Sheet stock may be lubricated prior to blanking or drawing. Regulators on reservoir provide precise adjustment of fluid pressure and nozzle pressure to allow accurate control of pattern size, preventing excessive oiling and over spray.

**FLUIDS ABOVE 750SSU AT 69° F (20.6°C) SUBJECT TO TESTING.**

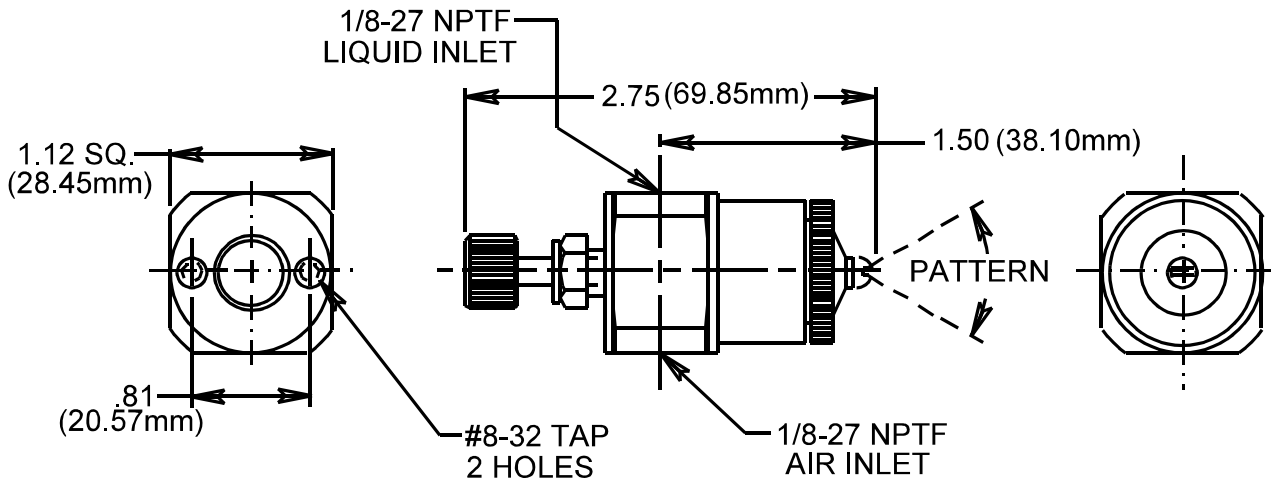

CATALOG NUMBER	SPRAY PATTERN	AIR		LIQ. PSI (kPa)	ANGLE A	SPRAY DIA. OR WIDTH AT A GIVEN DISTANCE FROM THE NOZZLE - DIMENSION IN INCHES (mm)						
		PSI (kPa)	SCFH (cu. m/H)			B	C	D	E	F	G	H
SV101	FLAT	22 (152)	60 (1.70)	10 (69)	-	3.00 (76.20)	6.00 (152.40)	10.00 (254.00)	13.00 (330.20)	18.00 (457.20)	-	-
SV102	ROUND	12 (83)	45 (1.27)	10 (69)	12°	-	-	1.30 (33.02)	1.90 (48.26)	3.20 (81.28)	3.60 (91.44)	3.80 (96.52)
		20 (138)	50 (1.42)	20 (138)	13°	-	-	1.40 (35.56)	2.10 (53.34)	3.40 (86.36)	3.90 (99.06)	4.10 (104.14)
SV103	WIDE ROUND	10 (69)	25 (.708)	10 (69)	-	-	-	5.50 (139.70)	7.00 (177.80)	9.00 (228.60)	-	-
		20 (138)	35 (.991)	20 (138)	-	-	-	6.00 (152.40)	7.50 (190.50)	9.50 (241.30)	-	-

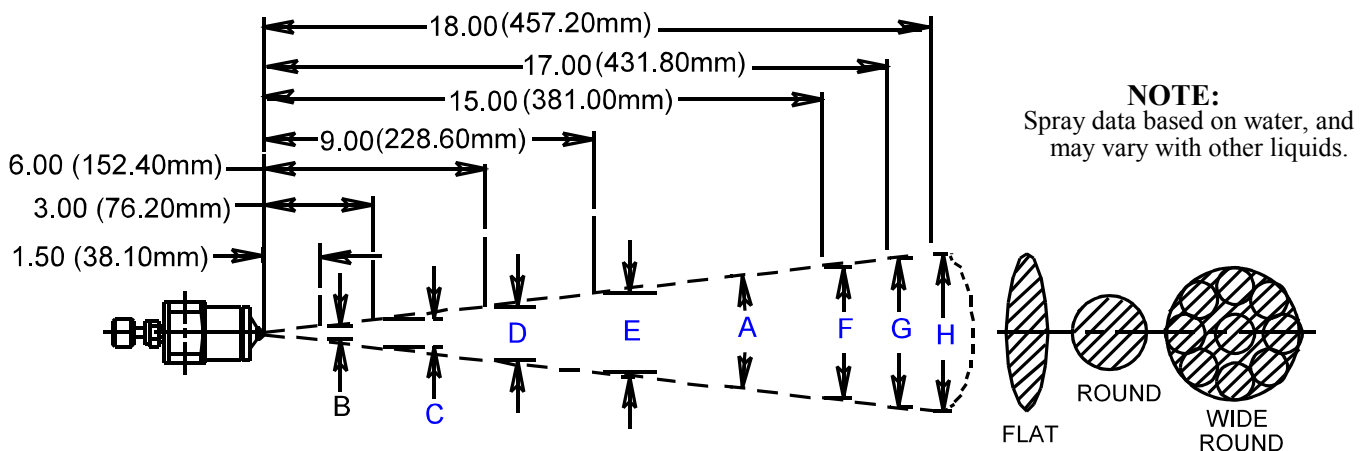

SPRAY VALVES  
ALUMINUM BODY/BRASS NOZZLE  
12/02 **BULLETIN F1127**

**LUBE DEVICES, INC.**  
1864 NAGLE AVE., P.O. BOX 1810, MANITOWOC, WI 54221-1810  
PHONE: (920) 682-6877 FAX: (920) 684-7210  
E-MAIL: sales@lubedevices.com WEBSITE: www.lubedevices.com