

LIQUID LEVEL GAGE - FRONT MOUNT, RIGID POLYMER, CARD THERMOMETER

LDI INDUSTRIES' GT623 series closed circuit liquid level gage is flush mounting, has a low profile and provides 180° viewing. This gage has a red thermometer on a white insert with dual scales of 0°F (-20°C) to +220°F (+110°C). This economical gage is suitable for many applications that require maximum fluid level visibility and temperature monitoring. For gage without thermometer, see our Series G623 on Bulletin F327-23A.

STANDARD MATERIALS:

- Tough, break resistant, transparent rigid polymer sight offers wide angle viewing
- Steel, zinc plated mounting bolts
- Buna N seals
- Black powder coated steel guard

OPERATING CONDITIONS:

- Maximum working pressure up to 100 PSIG (689 kPa) at 70°F (21.1°C)
- Maximum temperature up to 212°F (100°C)
- Suitable for use with most hydraulic and machine lubricating oils

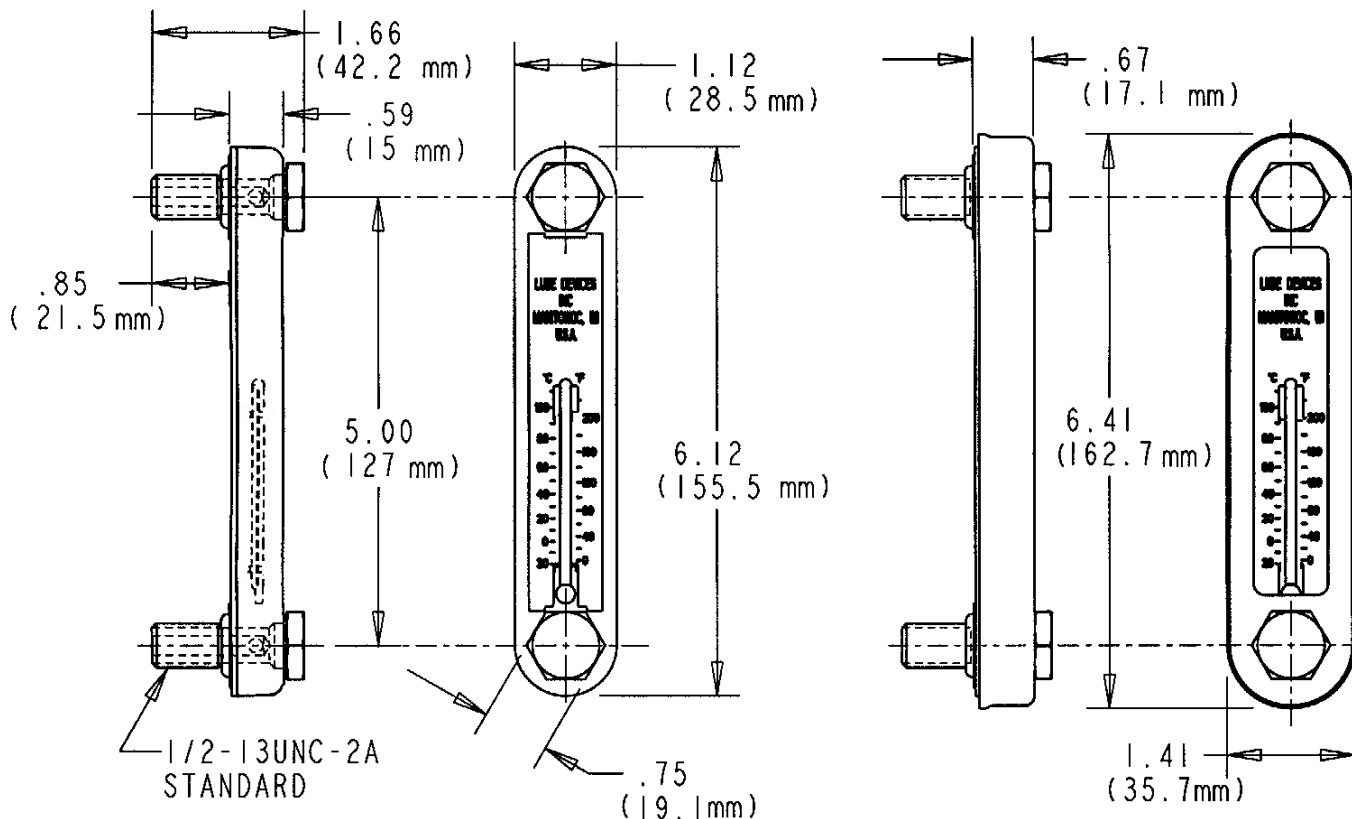

NOTE: Torque mounting bolts to 80 inch lbs. (9.04 N•m)

WITH OPTIONAL GUARD

HOW TO ORDER:

WHEN ORDERING, SPECIFY THE FOLLOWING AFTER THE SERIES NUMBER, SEPARATING EACH WITH A DASH (-):

- 1- Buna N seals (standard)
- 3- Viton A® seals (optional)
- M M12 x 1.75 bolts (optional)
- G Guard (optional)

EXAMPLE:

GT623-05-PG-1C — 1/2-13 UNC bolts, std
 Buna N seals
 Guard
 Polymer body, std
 5.00 (127mm) std mounting centers
 SERIES GT623

CAUTION: NOT RECOMMENDED FOR USE WITH: Alcohol or Steam condensate. For these fluids, our gages with BOROSILICATE sight glass and appropriate seals should be specified.

LIQUID LEVEL GAGE-FRONT MOUNT
 RIGID POLYMER, CARD THERMOMETER
 5/06 **BULLETIN F327-23B**
 ISO9001:2000 CERTIFIED



Lube Devices • Flodar • Hydra-Tool • Vescor
 1864 Nagle Ave. P. O. Box 1810
 Manitowoc, WI 54221-1810
 Phone: (920) 682-6877 Fax: (920) 684-7210
 E-MAIL: sales@ldi-industries.com WEBSITE: www.ldi-industries.com