

OIL GAGE -SHORT ELBOW WITH DRAIN .88 (22.35mm) SQUARE BASE

LDI INDUSTRIES' stocks a complete line of vented and pressure type oil gages. Gages are designed so they can be disassembled on site, the elbow alone installed, and the gage reassembled - A big plus when the installation is in a confined area. Protective gage shields can be rotated a full 360° for optimum viewing. The sight opening design allows for the lowest oil level reading possible. For positive sealing, the exclusive LDI Industries' pressure chamber construction employs two trepanned pressure bosses, one in the shank cavity and the other in the closure cap. This unique feature prevents lateral extrusion of the seals under compression and insures against leakers.

STANDARD MATERIALS:

- Brass construction
- Soda lime glass
- Buna N seals

OPERATING CONDITIONS:

- Maximum working temperature with standard seals up to 250°F (121.1°C)

**MODIFICATIONS AVAILABLE MADE TO ORDER - CONSULT OUR FACTORY
(MINIMUM ORDER MAY BE REQUIRED)**

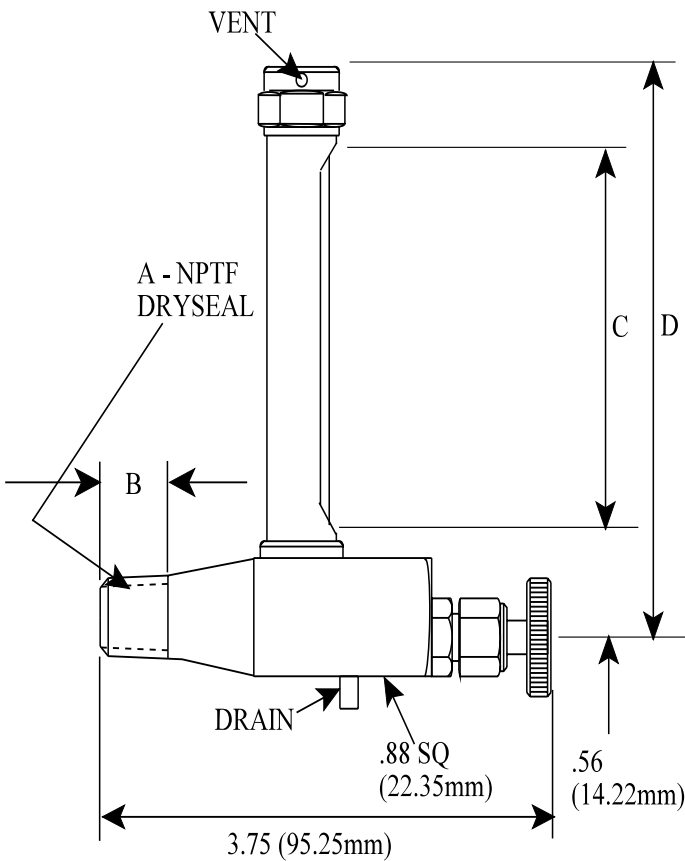

CATALOG NUMBER	A NPTF	B INCHES (mm)	C INCHES (mm)	D INCHES (mm)
G901-3	3/8	.56 (14.22)	4.25 (107.95)	5.44 (138.18)
G901-4	1/2	.75 (19.05)	4.25 (107.95)	5.44 (138.18)
G903-3	3/8	.56 (14.22)	7.50 (190.50)	8.69 (220.73)
G903-4	1/2	.75 (19.05)	7.50 (190.50)	8.69 (220.73)
G905-3	3/8	.56 (14.22)	12.25 (311.15)	13.69 (347.73)
G905-4	1/2	.75 (19.05)	12.25 (311.15)	13.69 (347.73)

<p>OIL GAGE-SHORT ELBOW WITH DRAIN .88 (22.35mm) SQUARE BASE</p> <p>5/06 BULLETIN1927-12</p> <p>ISO9001:2000 CERTIFIED</p>		<p>Lube Devices • Flodar • Hydra-Tool • Vescor</p> <p>1864 Nagle Ave. P. O. Box 1810 Manitowoc, WI 54221-1810</p> <p>Phone: (920) 682-6877 Fax: (920) 684-7210</p> <p>E-MAIL: sales@ldi-industries.com WEBSITE: www.ldi-industries.com</p>
---	---	---